

S-125 draft data model

Draft is based on S-201 with additions from S-101. The draft is not complete and not all features are included in all drawings. The RadioStation- feature is added as an entry-point for future additions of S-240 and possibly AIS-related data.

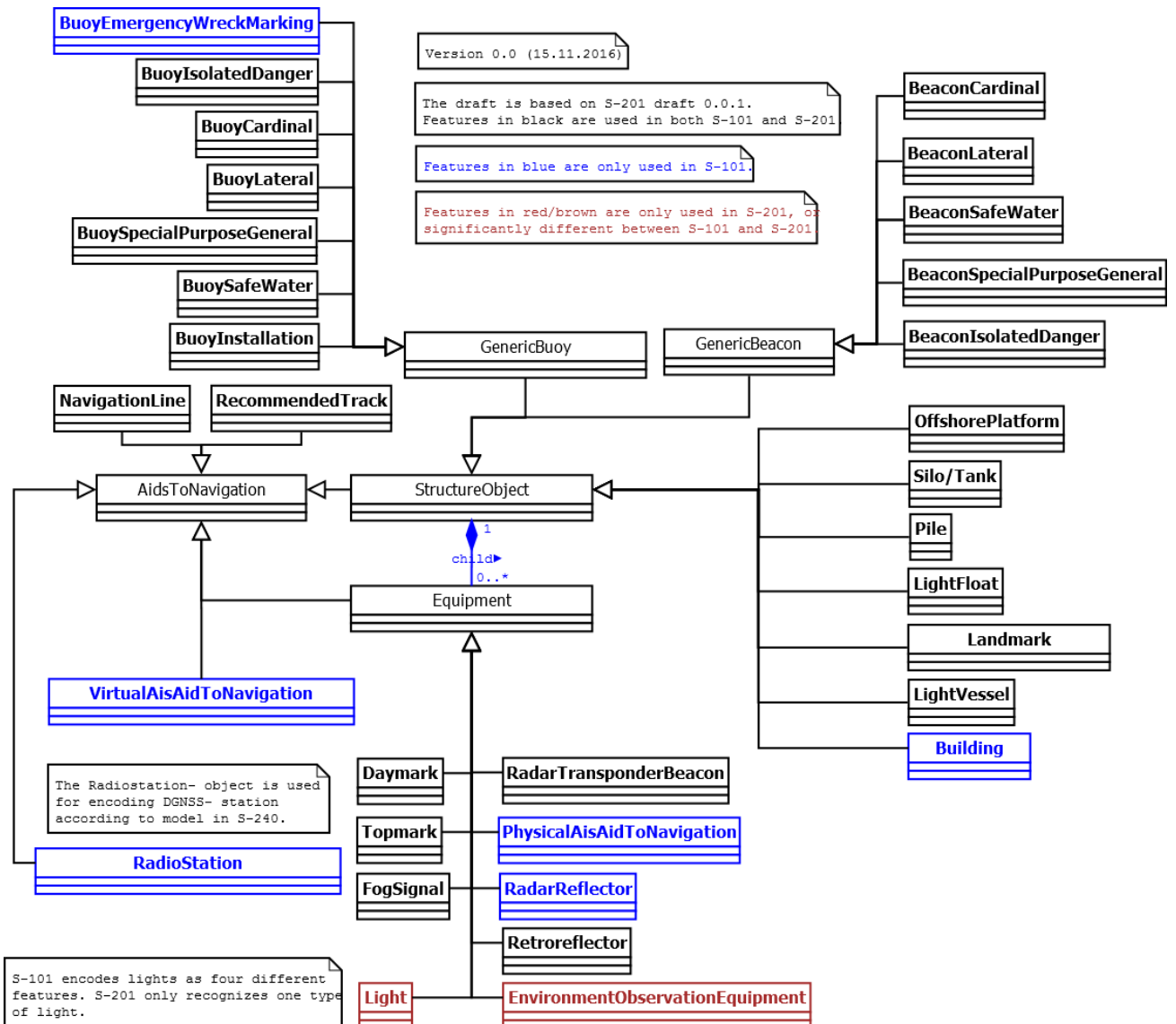

MRN in S-125

MRN is assumed to be encoded to the structure object of the Aids to Navigation. Each structure should have a unique MRN. Virtual AisAidToNavigation is not connected to a structure-object, and is given the MRN separately. MRN for VirtualAisAidToNavigation is optional.

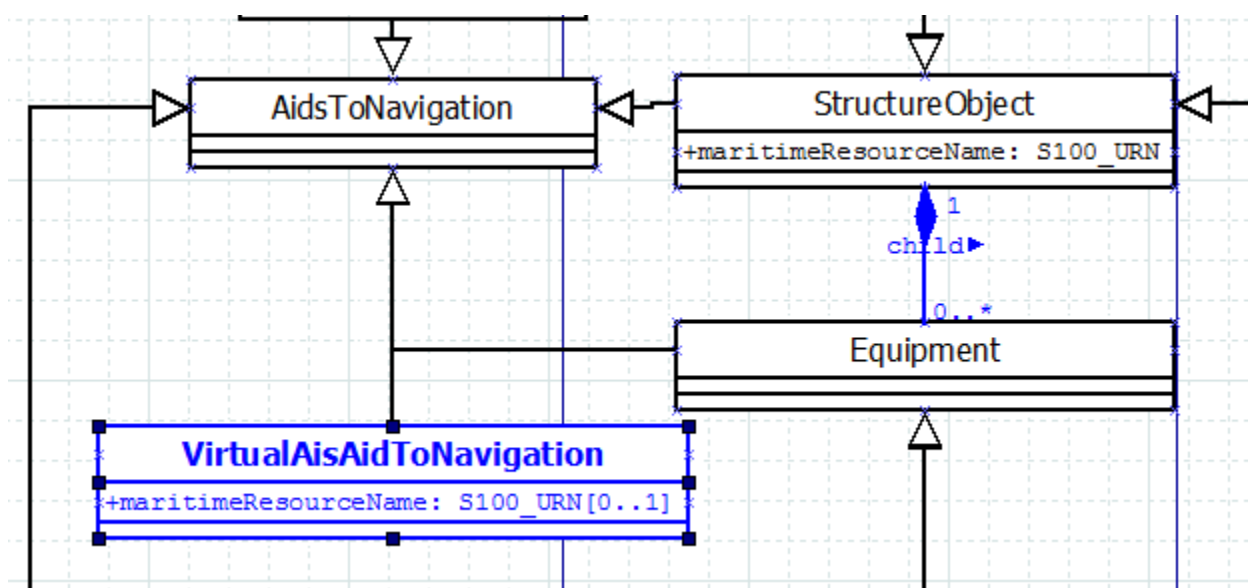

Additional light data 1/2

This is data additional to S-101 / S-201, needed in order to use S-125 as the source for a List of Lights. This data was previously identified by SHOM in a paper submitted as NIPWG 1-12.1. Attributes concerning Light numbers are excluded, as MRN is assumed to cover those.

Existing SNPWG attributes identified;

- additionalObjectName (ADDOBN)
- additionalBuildingOrLandmarkDescription (ADDBLD)
- additionalLightInformation (ADDLIT)

New attributes proposed;

- yearRelatedToStatus (STATYR)
- additionalDayMarkDescription (ADDMAR)
- morseLetterOfRacon (MORLET)
- rsxReference (rsxref)
- aisAton (aisatn)
- Completion of status attribute, to cover value 519 = "on trial"
- buildingType (buityp)
 - 1. Shelter
 - 2. House
 - 3. Building, block of flats
 - 4. Wall

Other additional data;

- Manual activation of Aids is encoded to the equipment.

Additional light data 2/2

Additional light data as encoded into the draft model as a part of S-125.

NOTE!
 aisatn object structure is adopted from S-101
 MORLET is not added, as equipment feature RadarTransponderBeacon has attribute signal group available for encoding morse letter.
 rsxref is not added at this point. This could be up for discussion. As the information is a string reference, perhaps the attribute additionalEquipmentInformation could be used.
 STATYR attribute and new status value "on trial" not yet added to model
 These additional attributes should maybe be considered as part of the "reported status" scheme drafted for S-125.

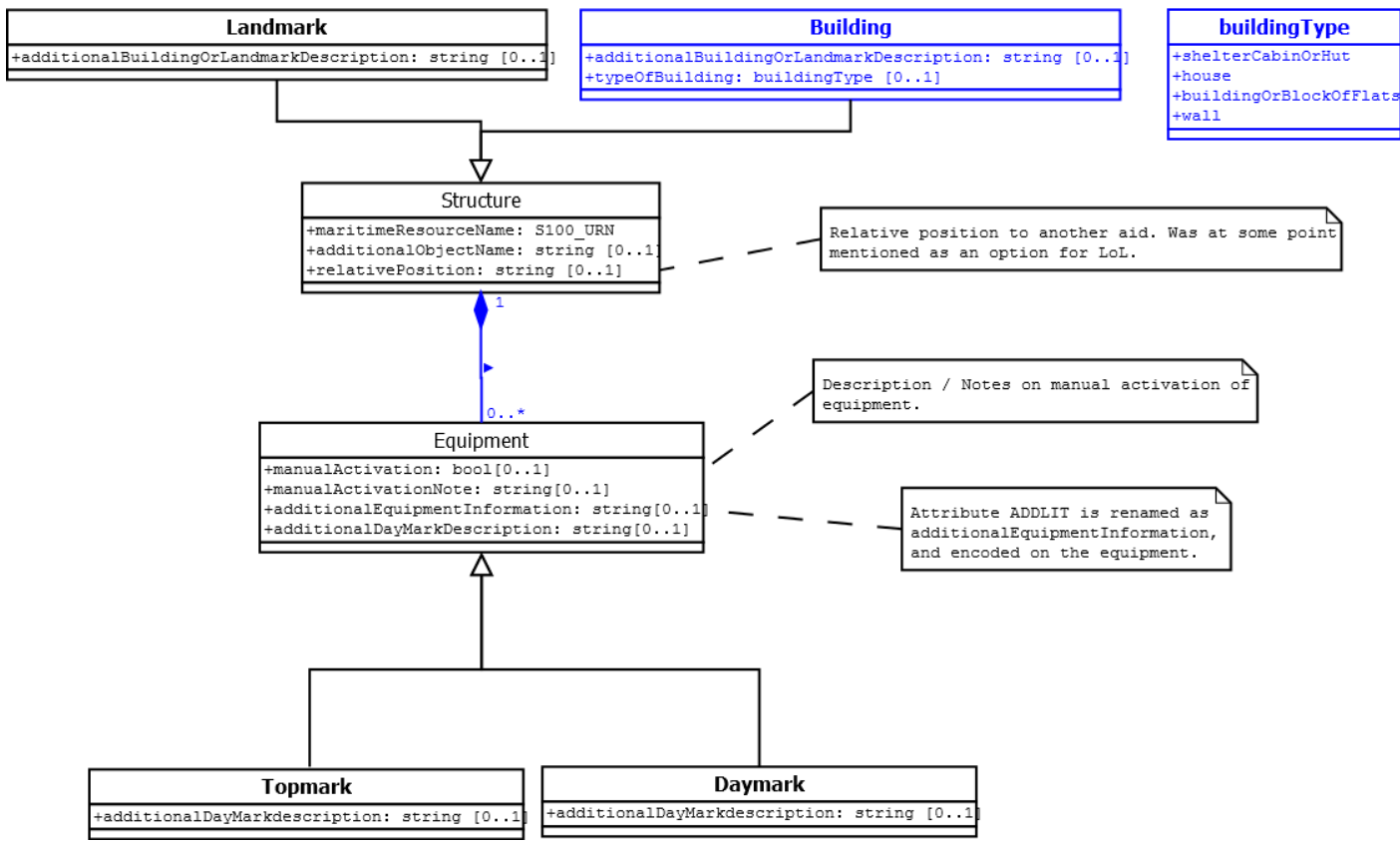

Seasonal replacement (Winter buoyage)

Seasonal replacement schedule is used for encoding the pre-known schedule of buoys replaced during winter or during ice-risk. The scheme could be extended to other purposes. Seasonal replacement is encoded on the GenericBuoy (= all buoys). Also an description and alternative position can be given.

The drafted enumeration values are based on data provided by BSH. An alternative position can be given for buoys scheduled for reposition. Additional constraints for usage might be needed.

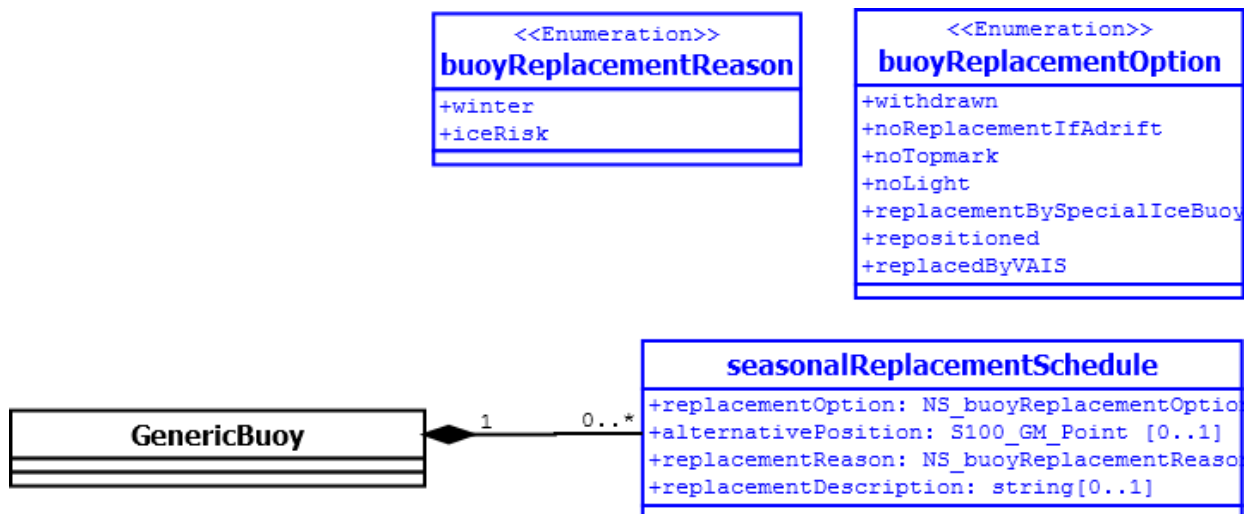

Current reported AtoN status

The reported status is a set of status reports encoded on the structure. The drafted scheme could absorb discrepancies and changes to AtoN's, as reported in USCG LNM section 2 and 3. but will need revision and additions.

